

10'

Plan View

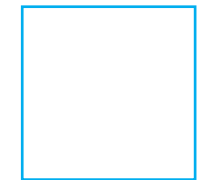
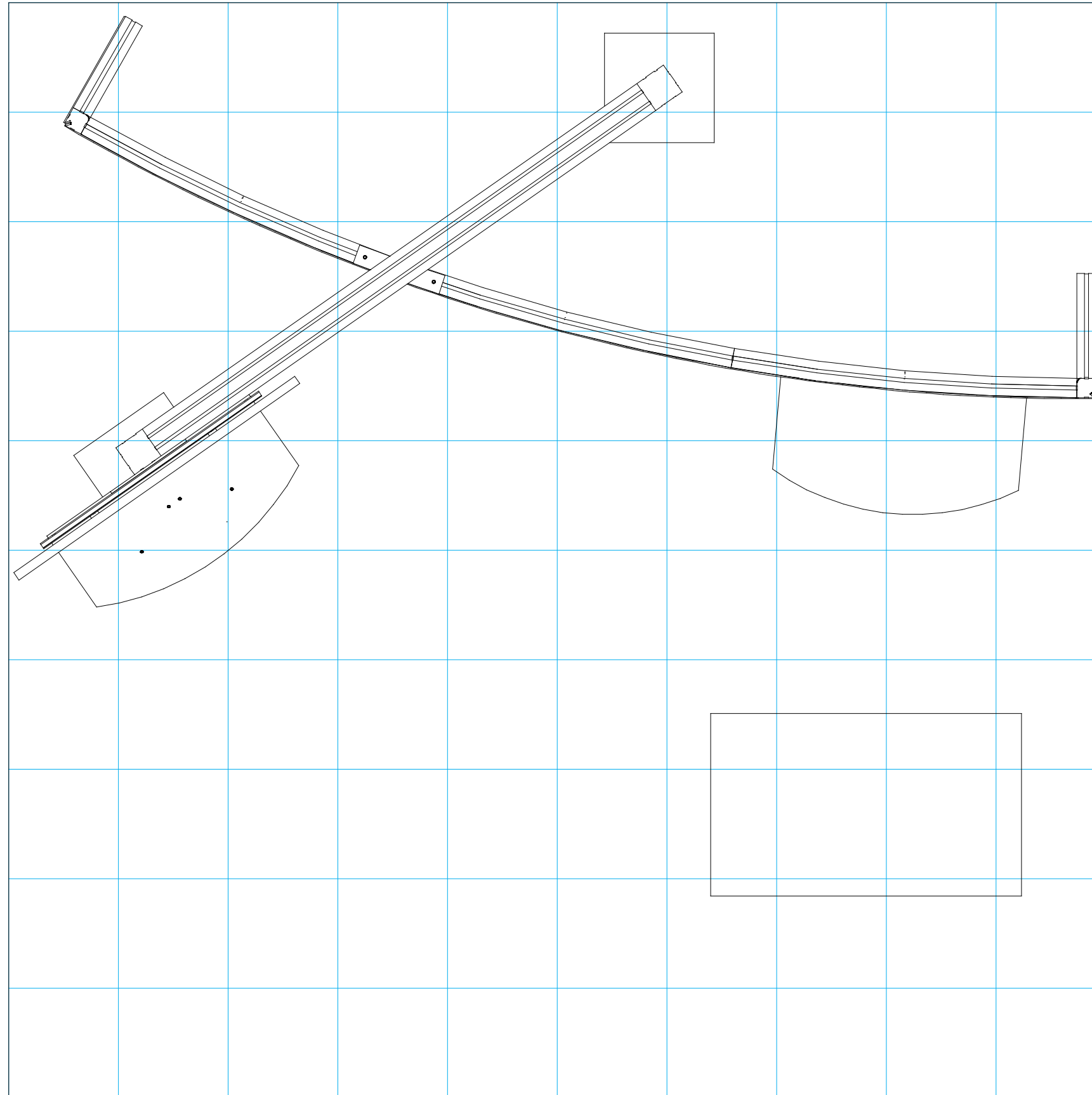

= 1 sq foot

General Setup Instructions

- Read entire setup instruction manual prior to unpacking parts and pieces.
- The setup instructions are created specifically for this configuration.
- Setup instructions are laid out sequentially in steps, including exploded views with detailed explanation for assembly.

Cleaning & Packing

- For Cleaning Metal, Plex, & Laminate Parts: Use a **MILD NON-ABRASIVE** cleanser and soft cloth/paper towel to clean all surfaces.
- Keep exhibit components away from heat and prolonged sun exposure. **Heat and UV exposure will warp and fade components.**
- Retain all provided Packing Materials. All provided packing materials are for ease of repacking & component protection.

Disassembly

- For loss prevention, tighten all set screws and locks during disassembly

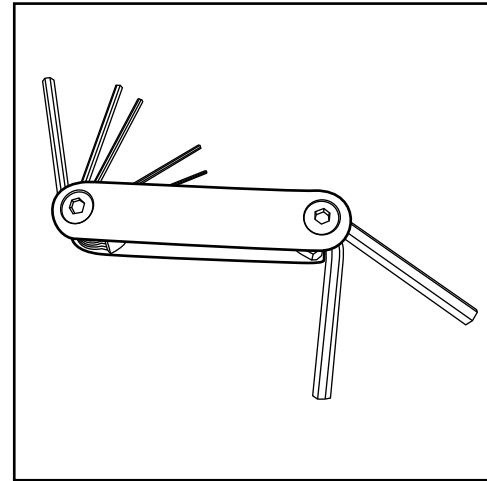

Hex Tool - Essential for Assembly

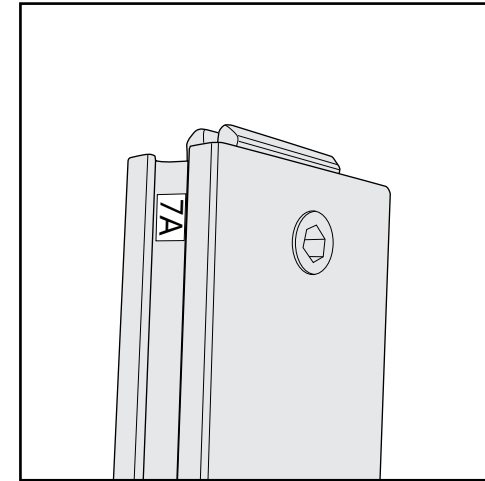

Part Identification - Numbering

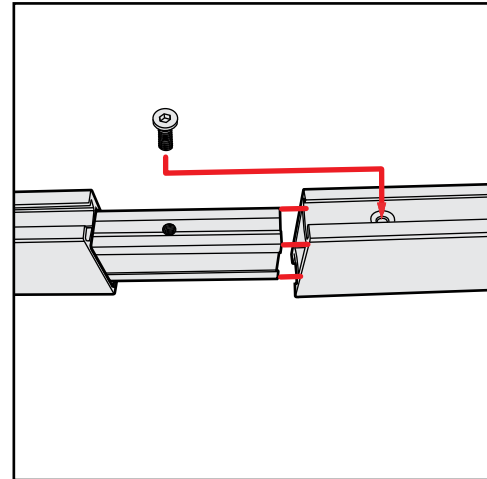

Spline Connection

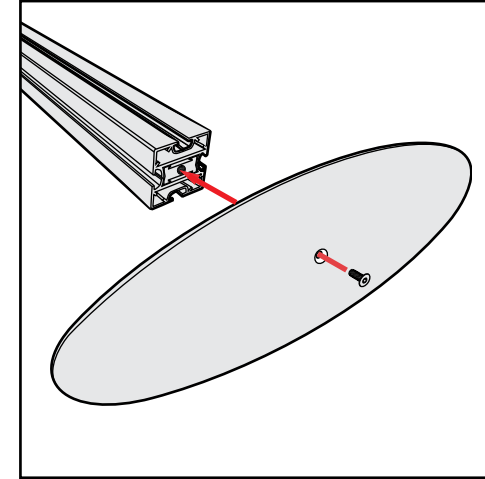

Base Plate & Extrusion Connection

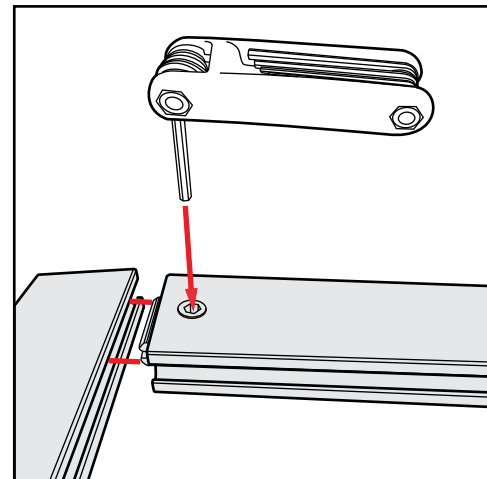

Extrusion & Lock Connection

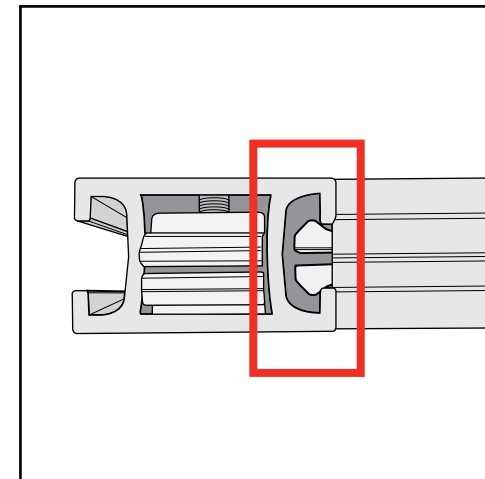

Engaged Lock



WARNING



DO NOT USE POWER TOOLS

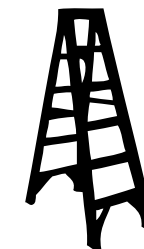

LADDERS OR LIFTS
MAY BE REQUIRED



ALL CONNECTIONS MUST
BE TIGHTLY SECURED

Side-by-Side Assembly

- 1) Frames: Place frames side-by-side with one higher than the other, then slide panel down to lock panels securely together.
- 2) Corner Connectors: Repeat Step 1 for installing corner connectors to frames.

Side-by-Side Disassembly

- 1) Pull pin lock outwards to disengage.
- 2) Pull frames upward and apart at the same time to detach.

Assembly

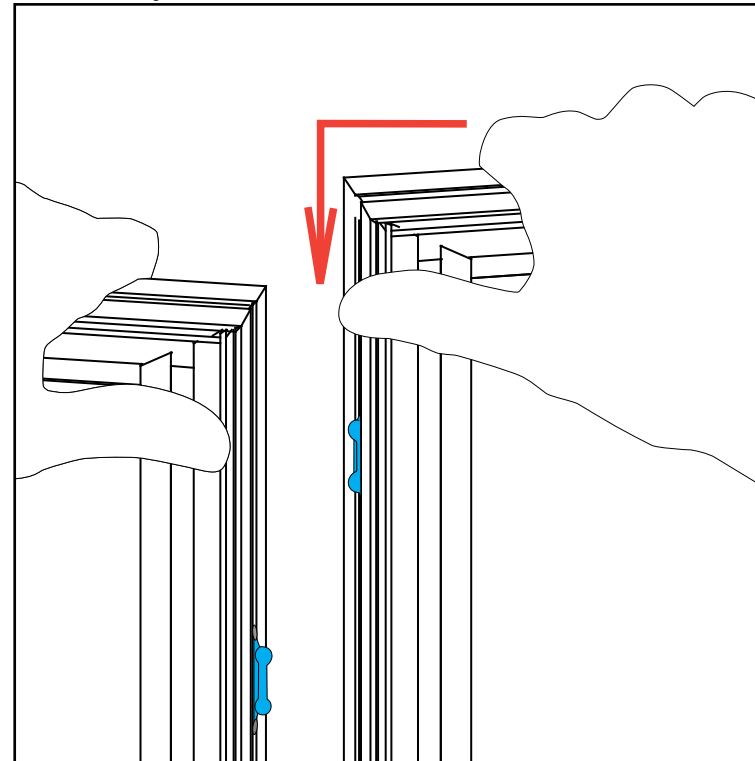

Assembly Cont'd

Push pin lock into hole of connecting frame.
Note: Block of pin lock will secure in groove.

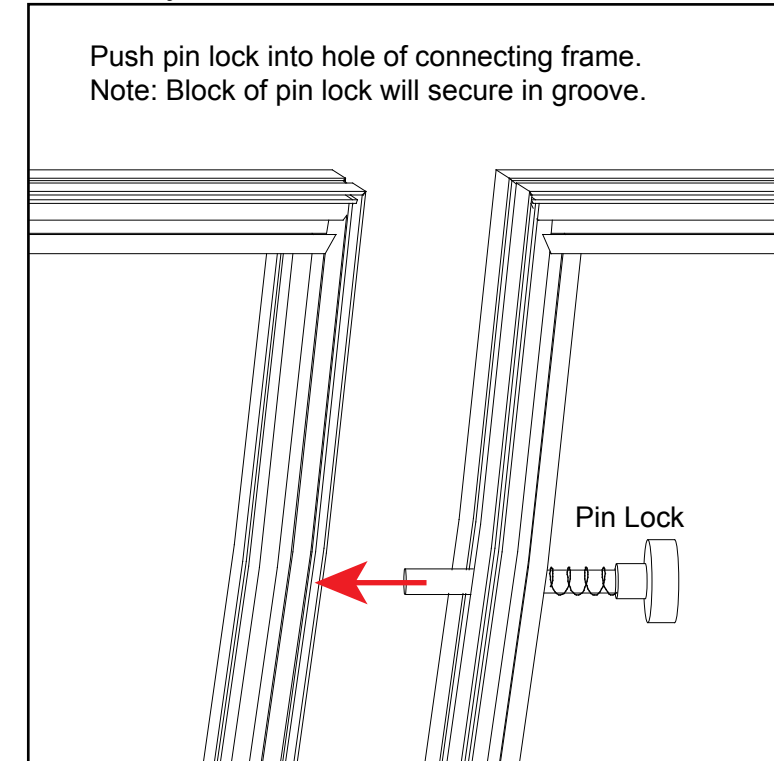

Corner Connector

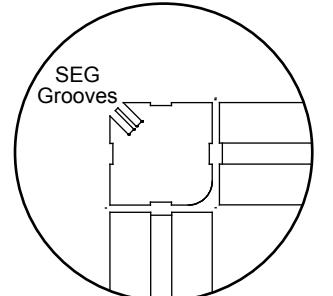

Top View
Note: Orientation of Corner Connector may change.

Stacking Assembly

- 1) Place one horizontal frame on top of the other, lining up the center grooves.
- 2) Turn stacking lock clockwise to tighten into place. Repeat for each lock.

Stacking Disassembly

- 1) Turn the stacking lock counter-clockwise to loosen.
- 2) The whole spring on the stacking lock should be in view to release each frame. The disengaged spring should release the stacking lock. If not, keep turning the stacking lock until it disengages.

Stacking

Push stacking lock into the slot of the upper frame, then spin the cap to tighten the lock.

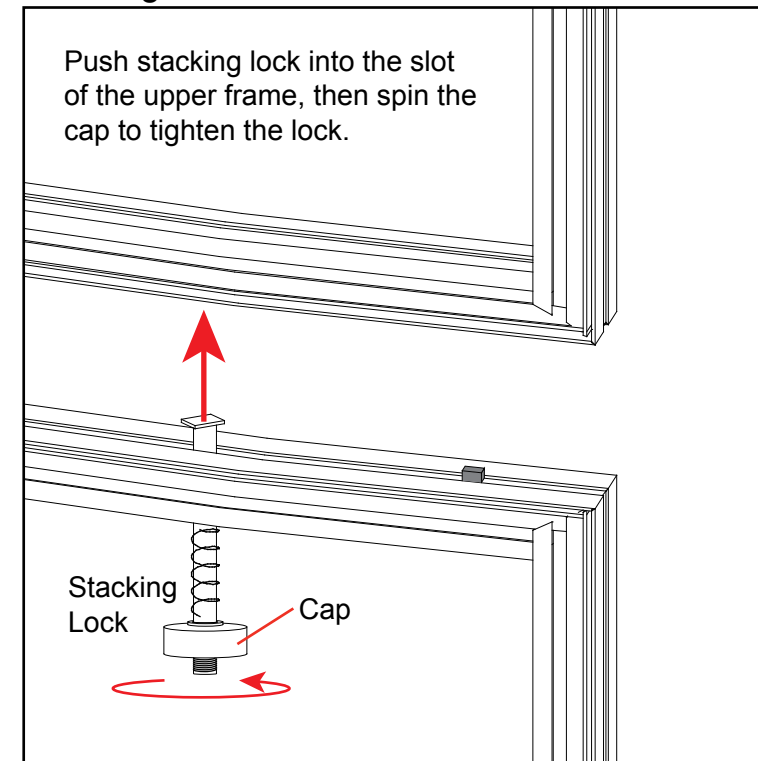

Unstacking

Disengage the stacking lock by spinning the cap counter clockwise and pulling down.

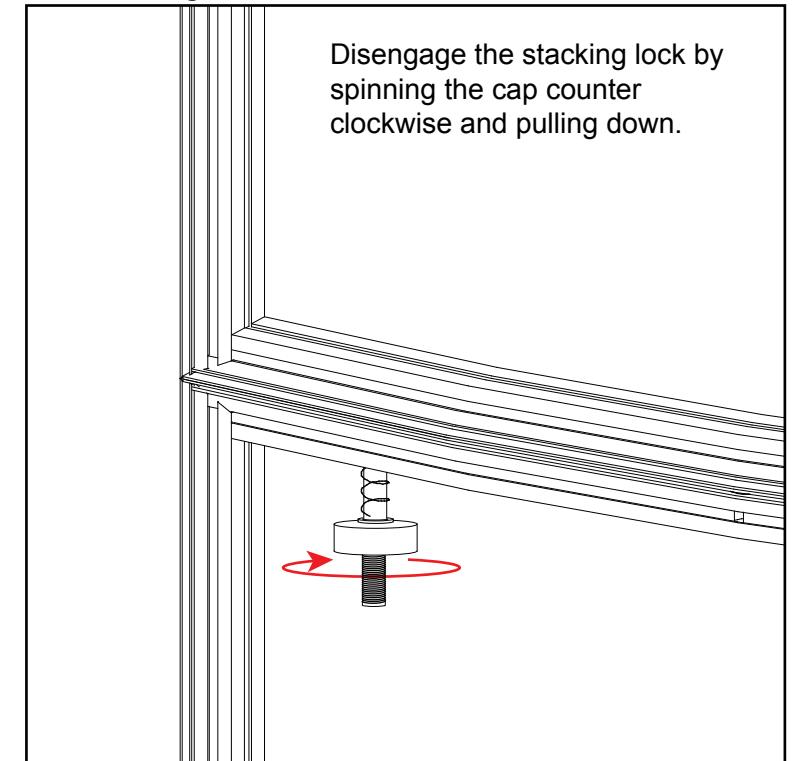

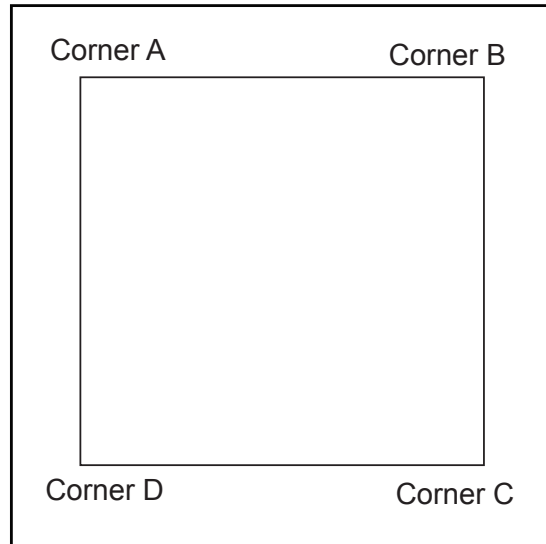

It is important to first insert graphic into each alternate corner then to the sides of the frame. If this is not done, graphic will not fit into the frame correctly.

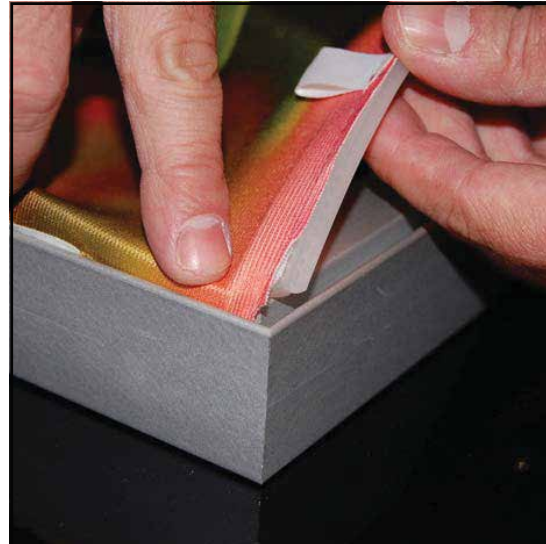

Step 1
Insert corner A. Turn edge of graphic so silicon welt is perpendicular to face of graphic. Insert narrow side of welt with fabric to outside into the channel. Repeat for other side of this corner.

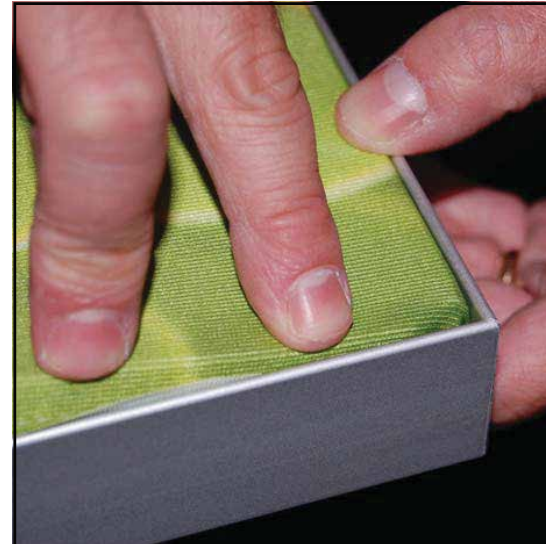

Step 2
Repeat Step 1 for opposite corner C, then insert corner B, followed by corner D, to complete the installation of the corners.

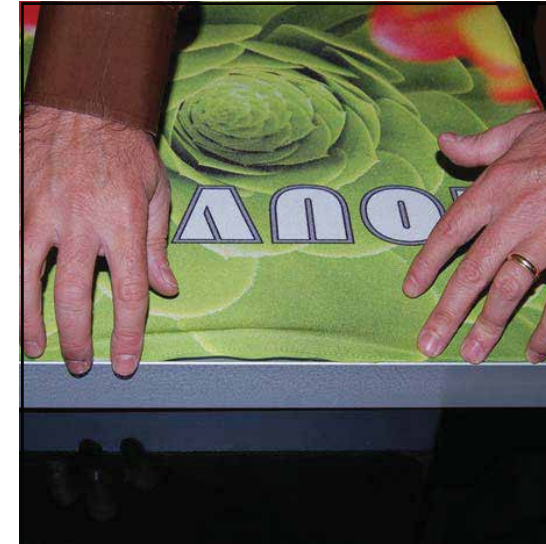

Step 3
Once all corners are inserted, press one silicon edge into channel from corners and work toward the center. Make sure welt is fully inserted into channel. Continue until all sides are done. Smooth out edges of graphic.

Graphic Removal

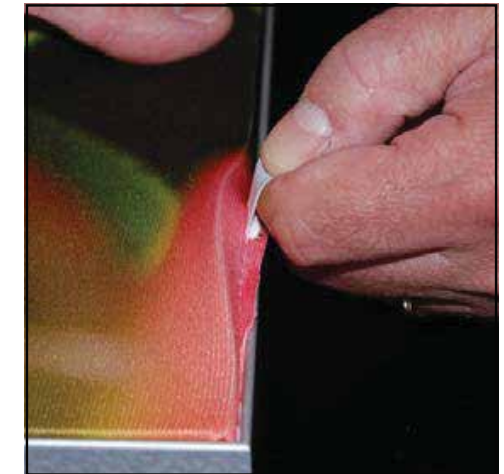

To remove the graphic from the frame, locate the fabric pull tab. Gently pull up on the tab to remove the fabric.

Item	Qty.	Description
1	1	11.5"w x 93"h Gravitee Panel
2	1	92.5"h Gravitee Post w/ caps
3	1	38"w x 93"h curved Gravitee Panel
4	1	38"w x 93"h curved Gravitee Panel
5	1	38"w x 93"h curved Gravitee Panel w/ S44
6	1	92.5"h Gravitee Post w/ caps
7	1	11.5"w x 93"h Gravitee Panel

Steps:

1) Assemble Gravitee panels & posts [1] through [7] together in numerical order as shown. Refer to the Gravitee Side-by-Side Assembly instructions in the general information pages.

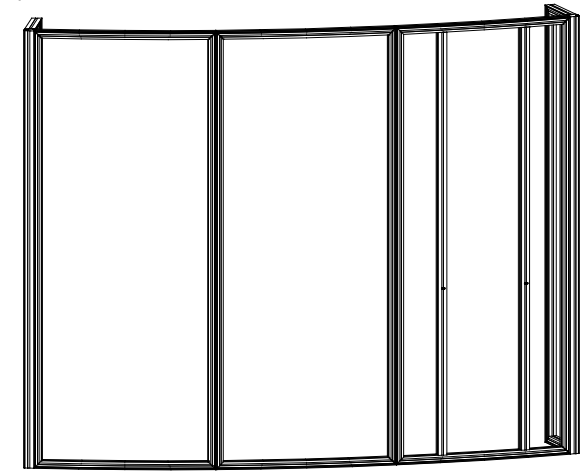

When assembled

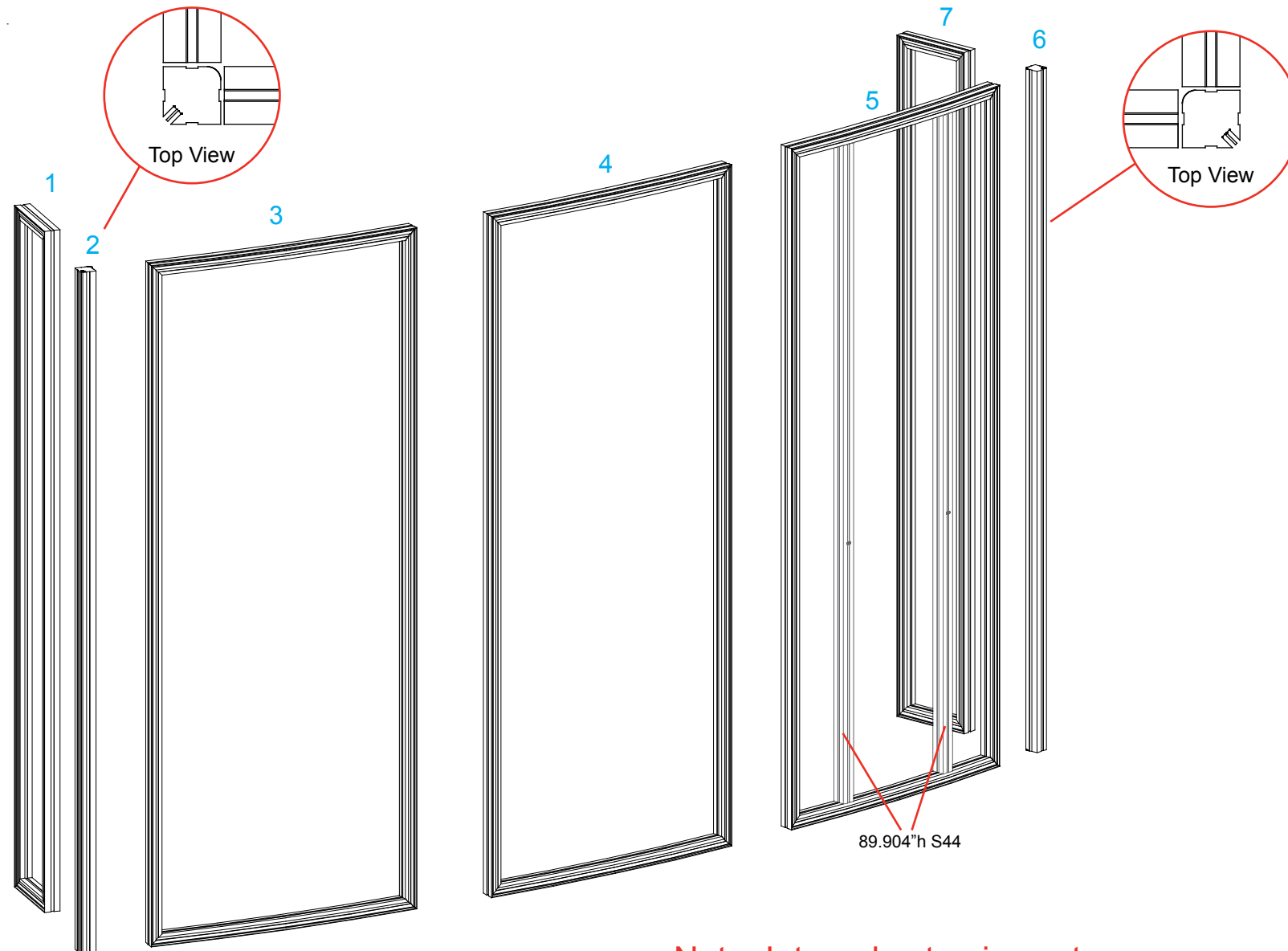

Note: Internal extrusions stay attached to Gravitee panels.
DO NOT DISASSEMBLE.

Item	Qty.	Description
1	2	12" x 12" Base Plate
2/2A	1/1	96.583"h Q918 Vertical Extrusion
3	1	66"w Z918 Horizontal Extrusion
--	1	23"w x 28"h x 18"d Workstation Cabinet
--	1	Custom Connector Plate

- Steps:
- 1) Attach Workstation Cabinet to vertical [2]. See [Workstation Attachment](#) detail.
 - 2) Install Base Plates [1] to verticals [2,2A], using bolts.
 - 3) Connect horizontal [3] between verticals [2,2A], and attach to top of Gravitee backwall using Custom Connector plate. See [Custom Plate Connection](#) detail.

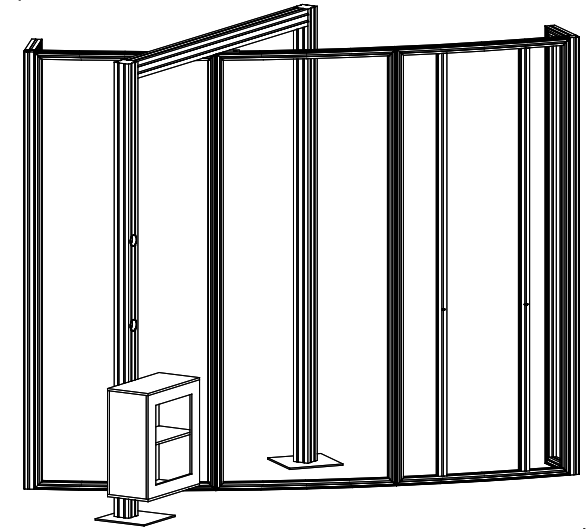

When assembled

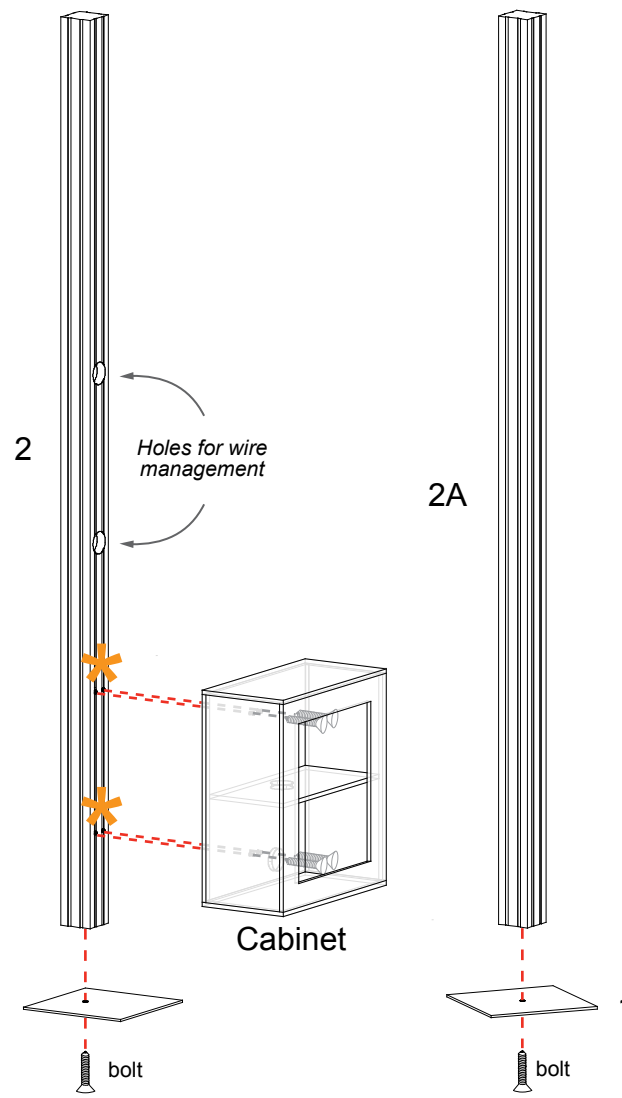

*** Workstation Attachment**

Slide V4 Connectors into groove of vertical extrusion; tighten set screws to secure connectors in place.

Attach Cabinet to connectors, using bolts.

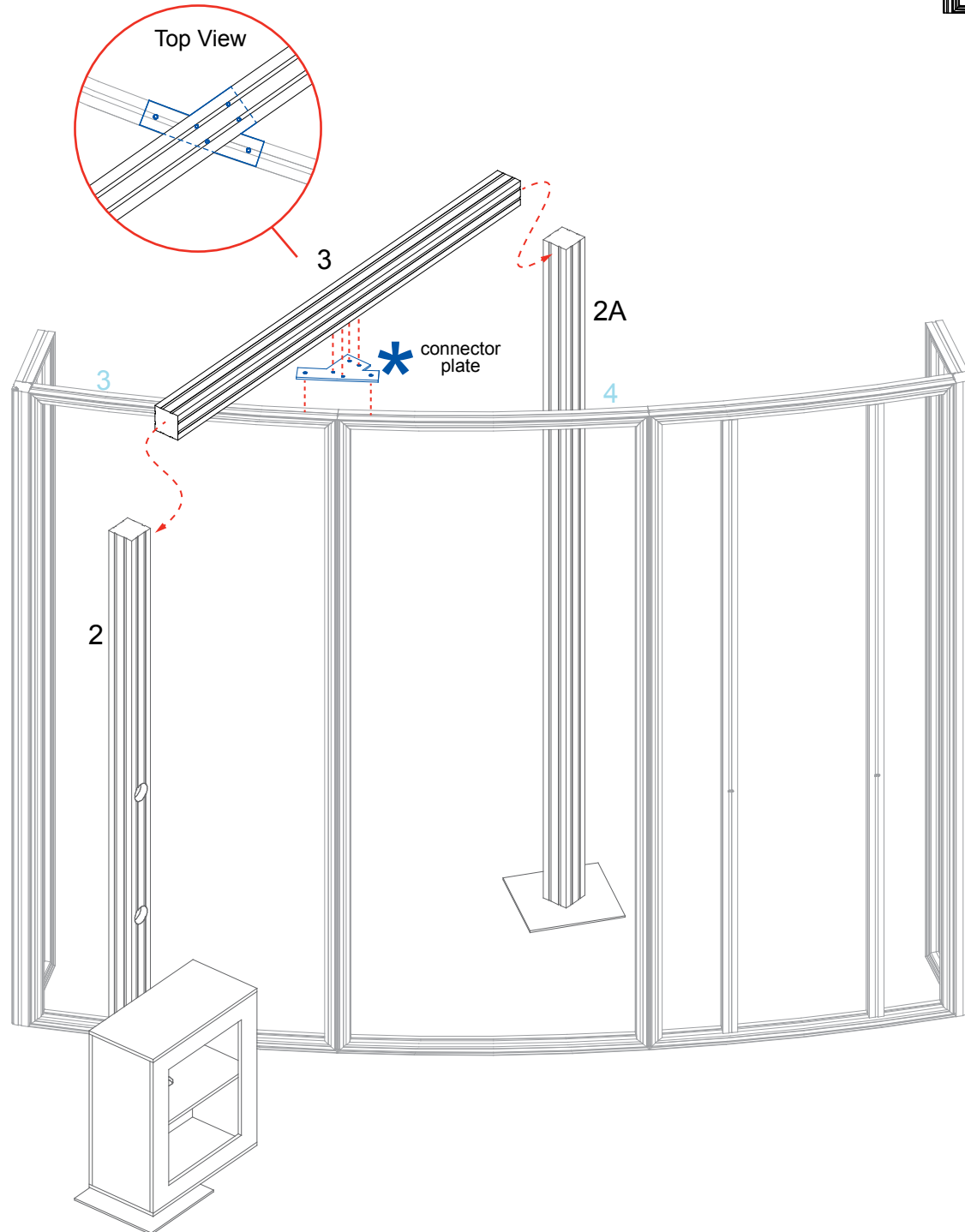

*** Custom Plate Connection**

- 1) Slide V4 connectors into grooves on underside of Q918 horizontal extrusion. Tighten set screws to secure connectors in place.
- 2) Attach Plate to V4 connectors using bolts.
- 3) Insert custom V4 connectors into top groove of backwall panels [3,4]. Tighten set screws to secure connectors in place.
- 4) Attach plate to connectors on top of backwall, using bolts.

Steps:

1) Apply SEG graphics to backwall assembly.

SEG Graphic Installation

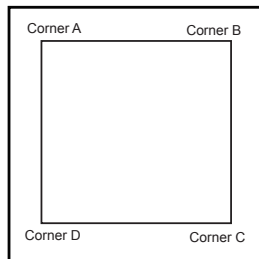

It is important to first insert graphic into each alternate corner, then to the sides of the frame. If this is not done, graphic will not fit into the frame correctly.

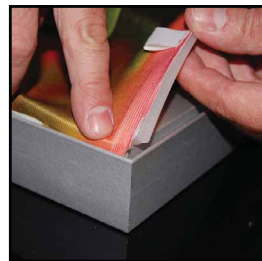

Step 1
Insert corner A. Turn edge of graphic so silicon welt is perpendicular to face of graphic. Insert narrow side of welt with fabric to outside into the channel. Repeat for other side of this corner.

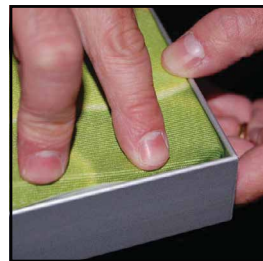

Step 2
Repeat Step 1 for opposite corner C, then insert corner B, followed by corner D, to complete the installation of the corners.



Step 3
Once all corners are inserted, press one silicon edge into channel from corners and work toward the center. Make sure welt is fully inserted into channel. Continue until all sides are done. Smooth out edges of graphic.

Graphic Removal

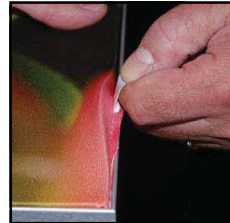

To remove the graphic from the frame, locate the fabric pull tab. Gently pull up on the tab to remove the fabric.

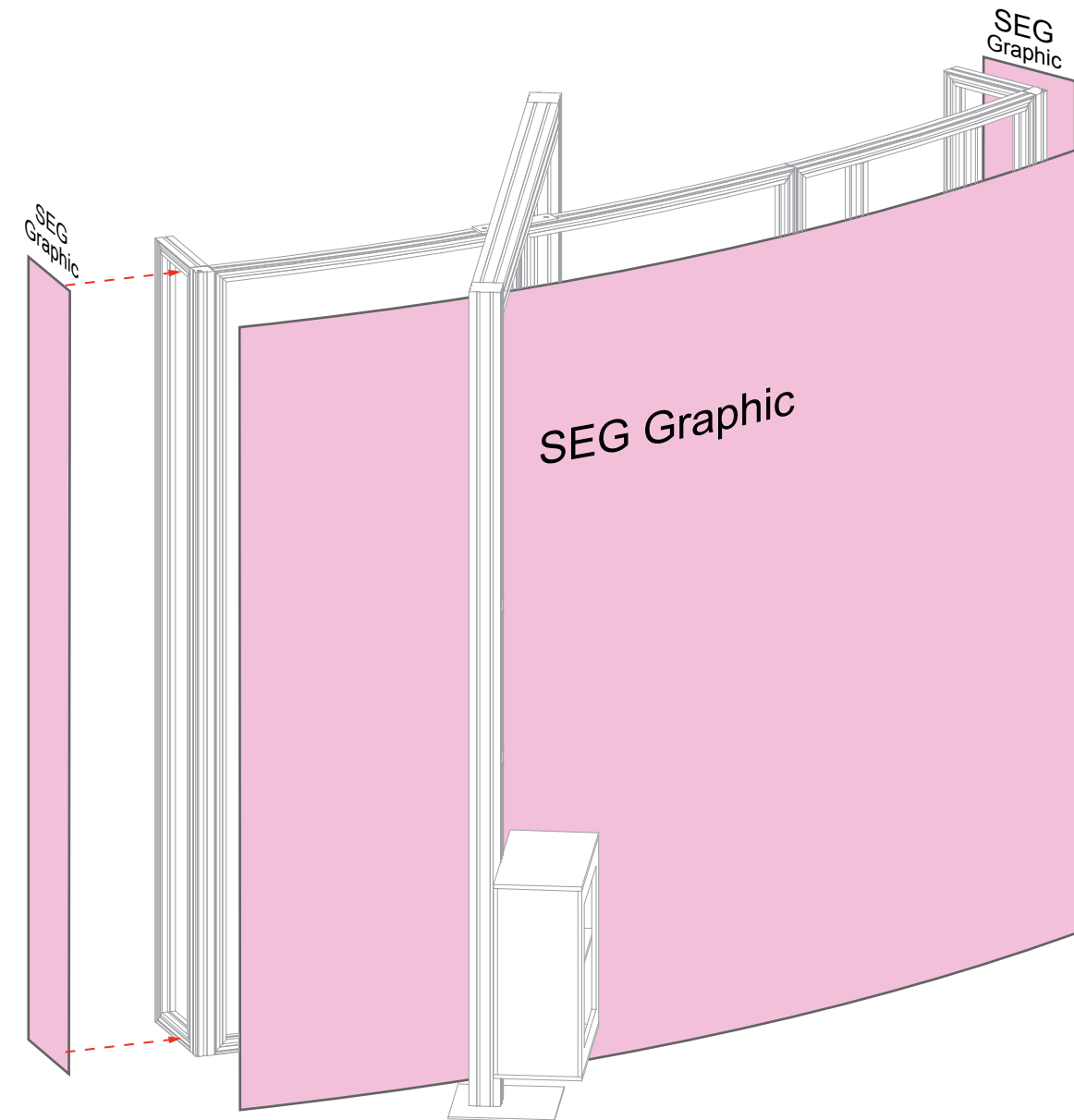

Note: Backwall shelf attaches to vertical extrusions of Panel [5] through the SEG graphic. See next step.

Item	Qty.	Description
1A	1	12" x 12" Base Plate
4	1	36.5"h Q914 Vertical Extrusion
--	1	27"w x 12.75"d Workstation Shelf w/ Z45
--	1	27"w x 14"d Backwall Shelf w/ Flange

Steps:

- 1) Install Monitor Mount to vertical [2]. See [Monitor Mount Attachment](#) detail.
- 2) Attach Workstation Shelf to vertical [2]. See [Workstation Shelf Attachment](#) detail.
- 3) Connect Base Plate [1A] to bottom of vertical [4], using bolt.
- 4) Attach Flange to top of vertical [4], then attach Backwall Shelf to flange. See [Flange Attachment](#) detail.
- 5) Connect Backwall Shelf to vertical extrusions in Panel [5]. See [Backwall Shelf Attachment](#) detail.
- 6) Attach lights to top of backwall panels [3,5] as shown. See [Light Attachment](#) detail.

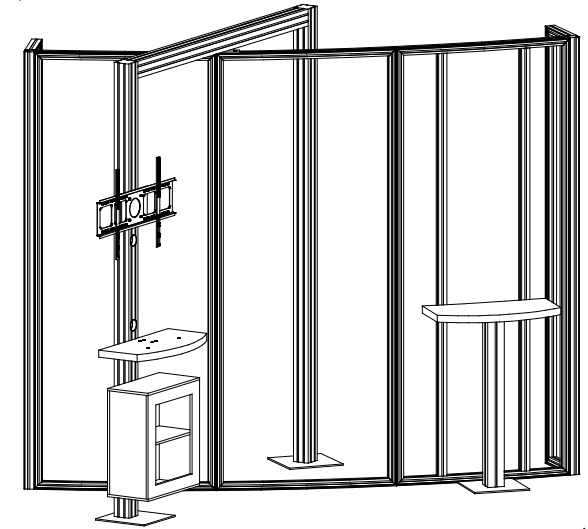

When assembled

*** Monitor Mount Attachment**

Slide V4 connectors into vertical channels of extrusions. Tighten set screws to secure.

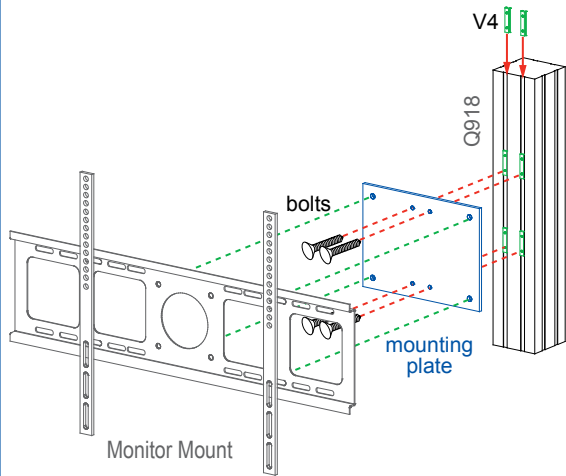
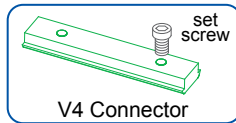

Attach Mounting Plate to V4 connectors, using screws. Then attach Monitor Mount to mounting plate.

*** Workstation Shelf Attachment**

Insert locks into grooves of vertical extrusion & tighten setscrews.

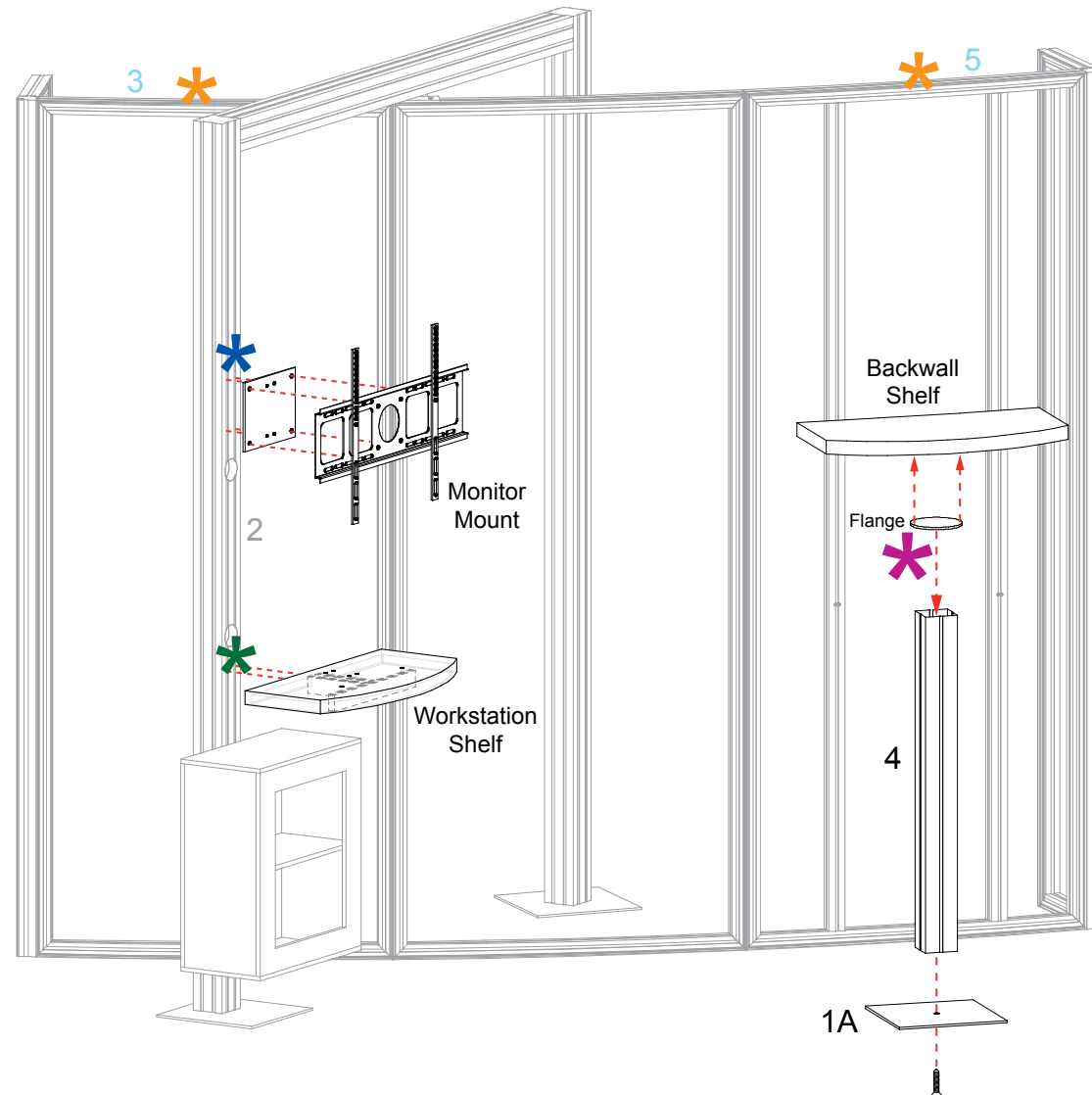
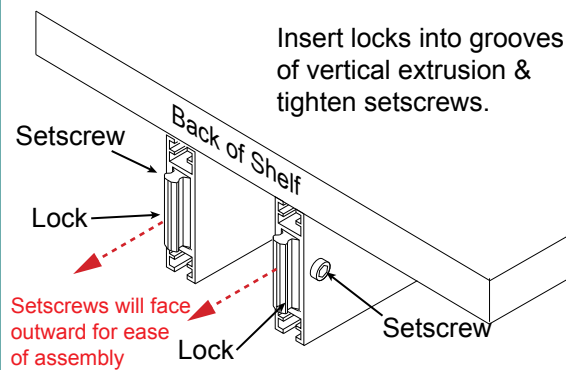

*** Light Attachment**

Lock Clip into Groove of Horizontal Extrusion, then slide Light onto Clip.

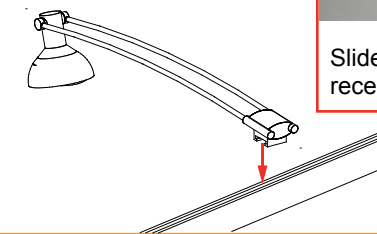

Slide light into light receiving hardware

*** Flange Attachment**

Insert screws located on underside of Shelf into holes on flange plate and secure with wing nuts.

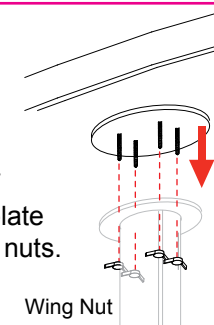

Wing Nut

Backwall Shelf Attachment

Slide V4 connectors into channels of vertical extrusions in Gravitee panel [5]. Tighten set screws to secure V4 connectors.

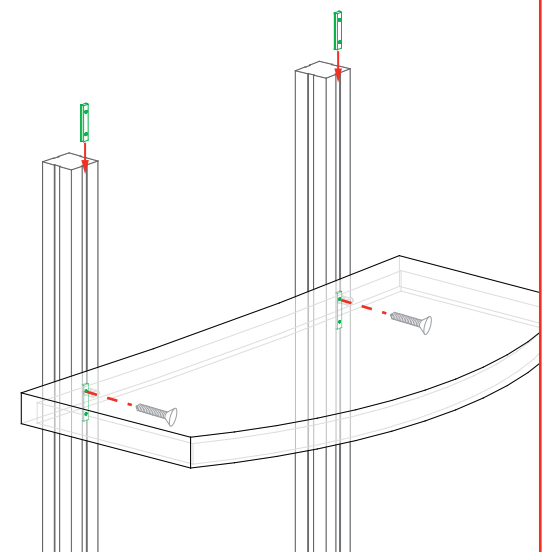

Attach Backwall Shelf to V4 connectors using bolts on underside of shelf.

Shelf attaches to V4 connectors through the SEG graphic.

Item	Qty.	Description
5	2	23.094" w Q914 Horizontal Extrusion
6	4	39" h Q914 Vertical Extrusion
--	1	23" w x 28" h x 18" d Cabinet

Steps:

Note: Assemble unit upside down, then turn upright to attach counter top.

- 1) Assemble horizontals [5] between verticals [6].
- 2) Attach Cabinet to verticals [6]. See Cabinet Attachment detail.
- 3) Turn unit upright & attach Counter Top.

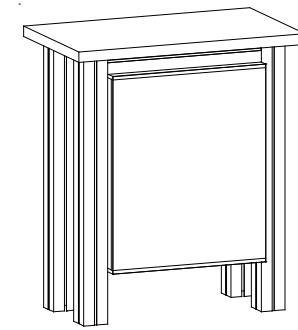

FRONT VIEW

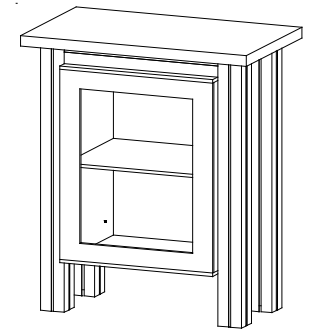

BACK VIEW

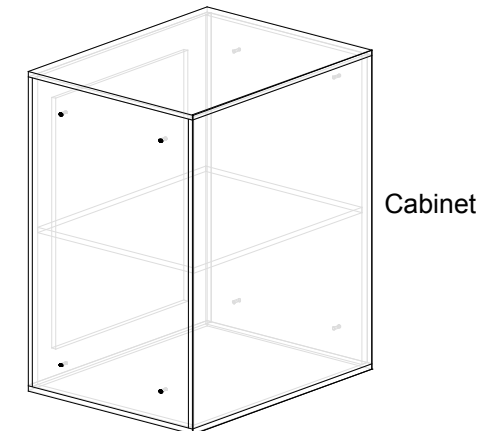
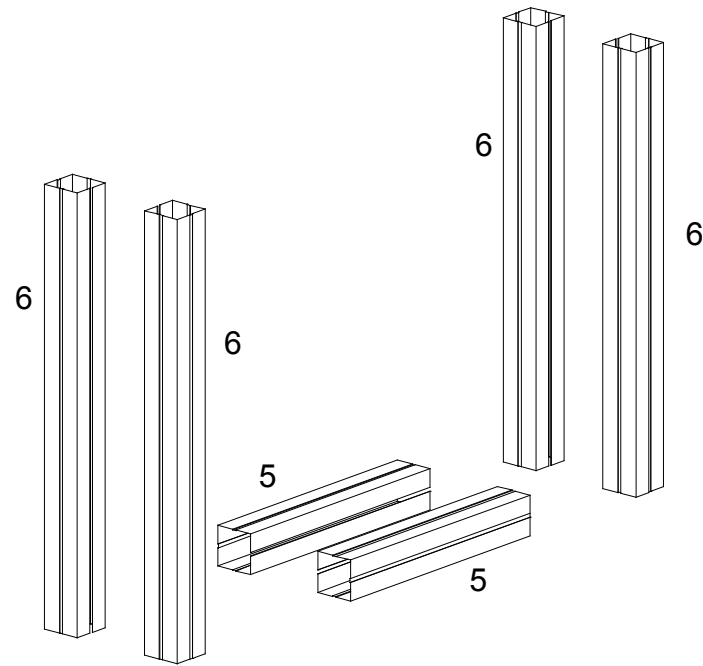

Cabinet

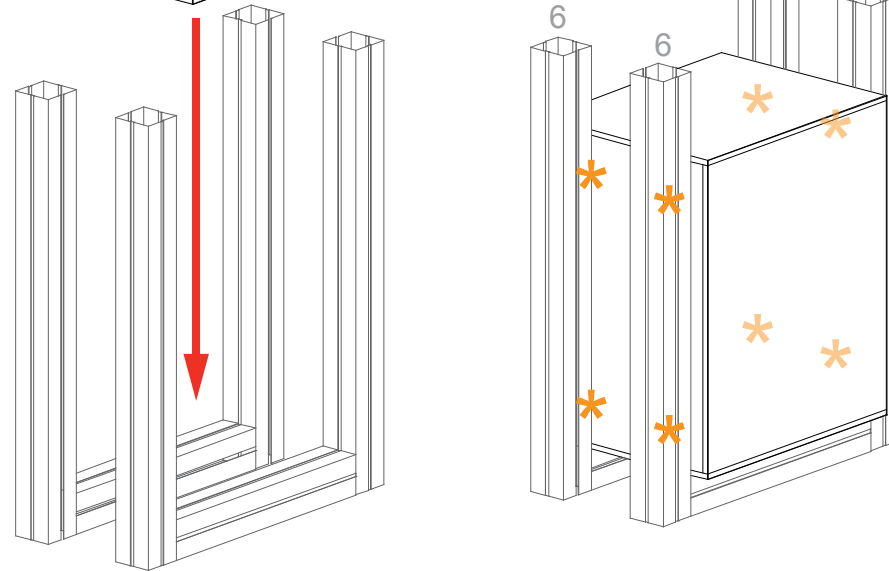

*** Workstation Attachment**

Slide V4 Connectors into groove of vertical extrusions; tighten set screws to secure connectors in place.

Attach Cabinet to connectors, using bolts.

When assembled

